

Pro-Fit Kit

Riser Rail Assembly

Available in 2 lengths - 530mm and 670mm

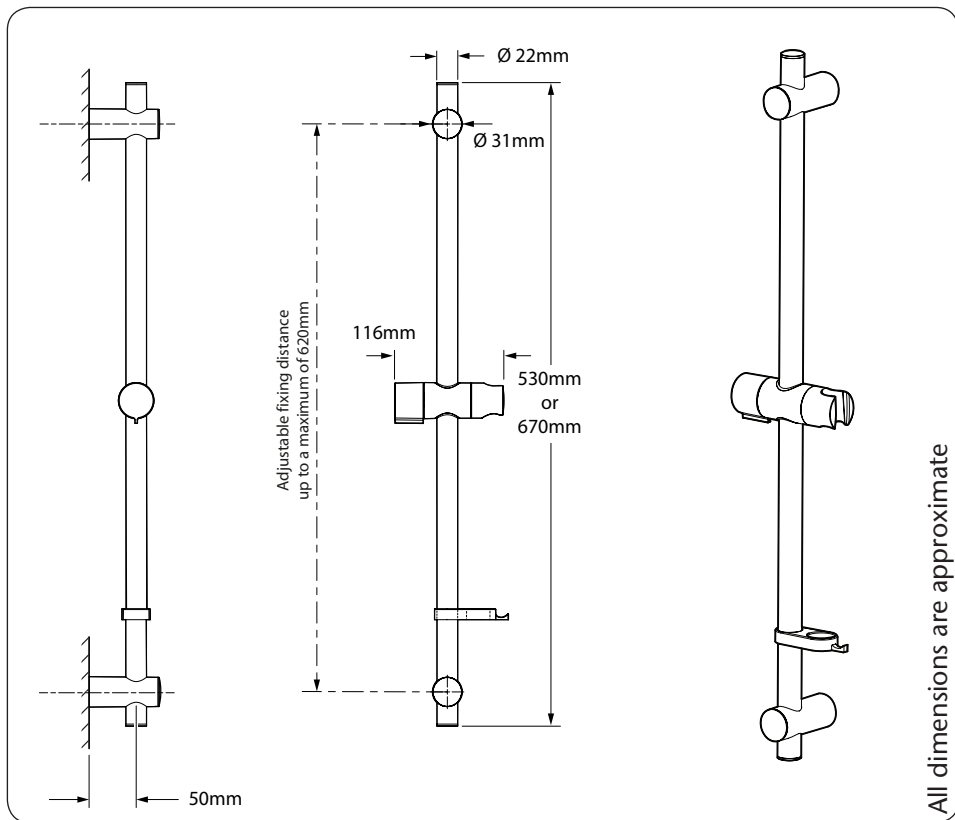

Installation Instructions

TRITON ALWAYS RECOMMEND THE USE OF GENUINE TRITON ACCESSORIES FOR USE WITH A TRITON SHOWER. FAILURE TO USE GENUINE TRITON PARTS MAY INVALIDATE YOUR GUARANTEE.

INSTALLERS: PLEASE NOTE THESE INSTRUCTIONS ARE TO BE LEFT WITH THE USER.

FITTING THE RISER RAIL ASSEMBLY

Fig. 1

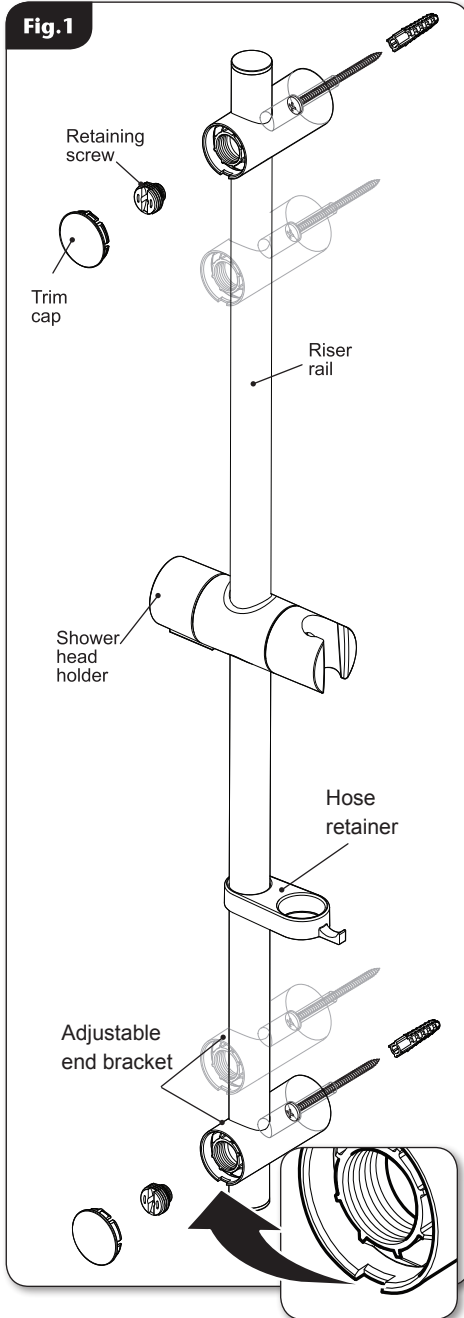

WARNING!

Check there are no hidden cables or pipes before drilling holes for wall plugs. Use great care when using power tools near water. The use of a residual current device (RCD) is recommended.

Important: This riser rail assembly has two adjustable wall brackets allowing full flexibility during the installation process.

- Using the riser rail as a guide, decide on the position for the rail within the shower area.
- Offer one of the brackets to the wall. Place the bracket in the lower position and mark the centre hole. Remove the bracket then drill and plug the wall. The wall plugs provided are suitable for most brick walls. Use an appropriate drill bit, but if the wall is plasterboard or a soft building block, you must use suitable wall plugs.
- Tighten the bracket onto the wall using the screws provided but do not tighten fully.
- Offer upper bracket to the wall and measure vertically from the centre of the bottom hole and mark. Remove the bracket then drill and plug the wall. **(fig.1)**.
- Tighten the brackets onto the wall using the screws provided, but do not tighten fully.

Note: The brackets have a notch in them - inset of **fig.1**. This should be in the 6 o'clock position on the bottom bracket and in the 12 o'clock position on the top bracket.

- Insert the riser rail through either the top or bottom bracket and slide into place. Some minor adjustment may be needed to allow the riser rail to be inserted into the opposite end bracket. Once both brackets have been aligned, remove the riser rail and tighten them fully.

FITTING THE RISER RAIL ASSEMBLY

- Refit the riser rail and install the shower head holder and hose retainer (**fig.2**).
- Fit the showerhead holder onto the riser rail as follows: Twist counter-clockwise to release the locking mechanism then slide the holder onto the rail. Simply twist clockwise to secure holder in place (**fig.2**).
- Slide the hose retainer onto the bottom of the riser rail below the holder (**fig.2**).
- Once the holder and hose retainer are in place, the riser rail will need to be secured. Slide the riser rail into the bottom bracket and insert the first retaining screw (**fig.3**).
- Repeat the procedure for the top bracket. **Note:** Loosening off the top and bottom retaining screws will allow the riser rail to be adjusted to the position required (**fig.3**).
- Once in position, re-tighten the retaining screws and fit the trim caps (**fig.4**).

FITTING THE HOSE AND SHOWERHEAD

Feed the flexible hose through the opening in the hose retainer (**fig.5**) The hose retainer **MUST** be used to comply with Water Regulations.

Screw the flexible hose to the shower outlet and showerhead, making sure the supplied washers are in place at both ends of the flexible hose (**fig.6**).

Place the showerhead into the holder and check that it fits correctly (**fig.7**).

Note: The holder is slightly tapered and the showerhead and hose will only fit from one direction.

IMPORTANT: It is the conical end of the hose which grips into the holder. The showerhead will not fit in the holder without the hose attached.

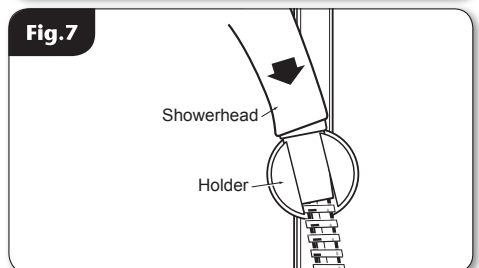
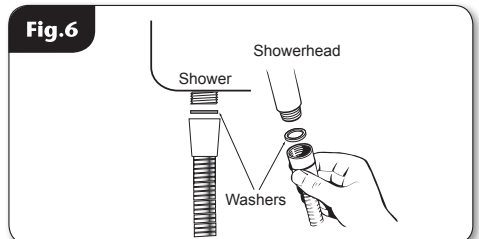
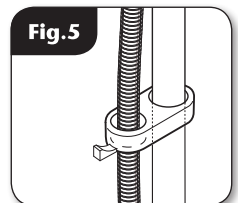
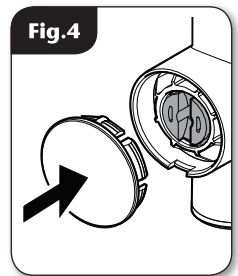
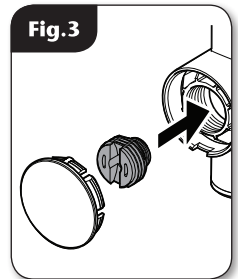
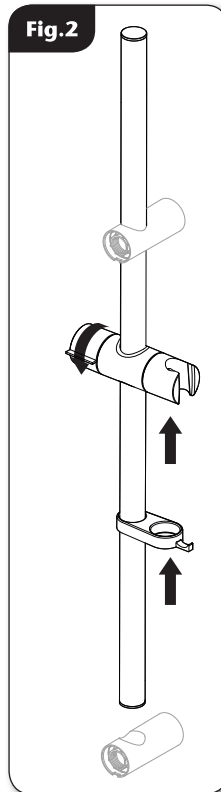

SPARE PARTS

<i>Ref. Description</i>	<i>Spares No.</i>
A Bracket and trims (pair), screws & raw plugs included	
White	86005240
Chrome	86005250
B Riser rail	
530mm	
Chrome	88800051
Stainless Steel	88800052
670mm	
Chrome	88800049
Stainless Steel	88800050
C Showerhead holder	
White	22013390
Chrome	22013400
D Hose Retainer	
clear	22013450

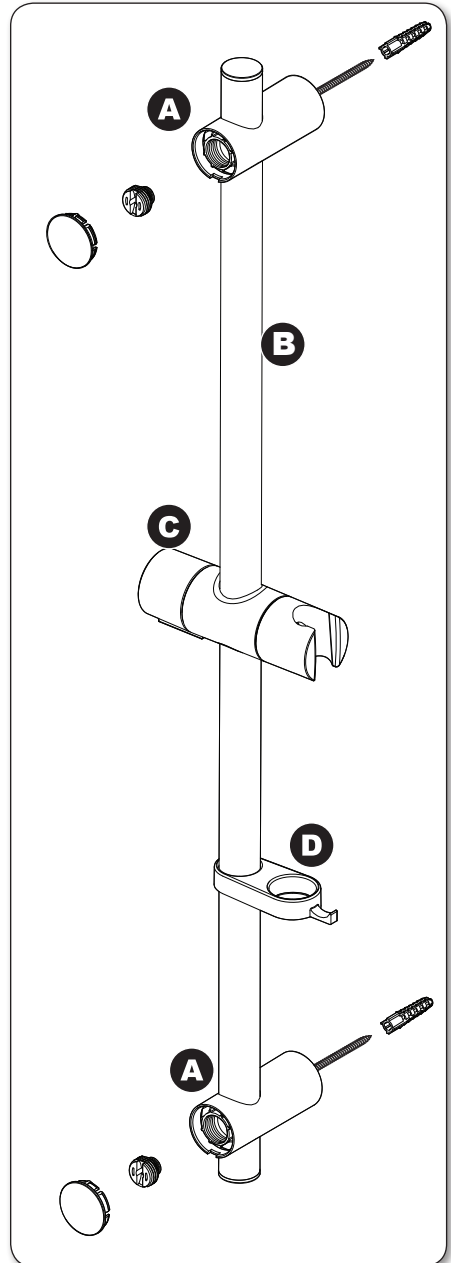

Please refer to shower installation and operating instructions for service details