

Product Name: DUAL
Product Ref: DL115
Art number: 406083/84/85/86/87

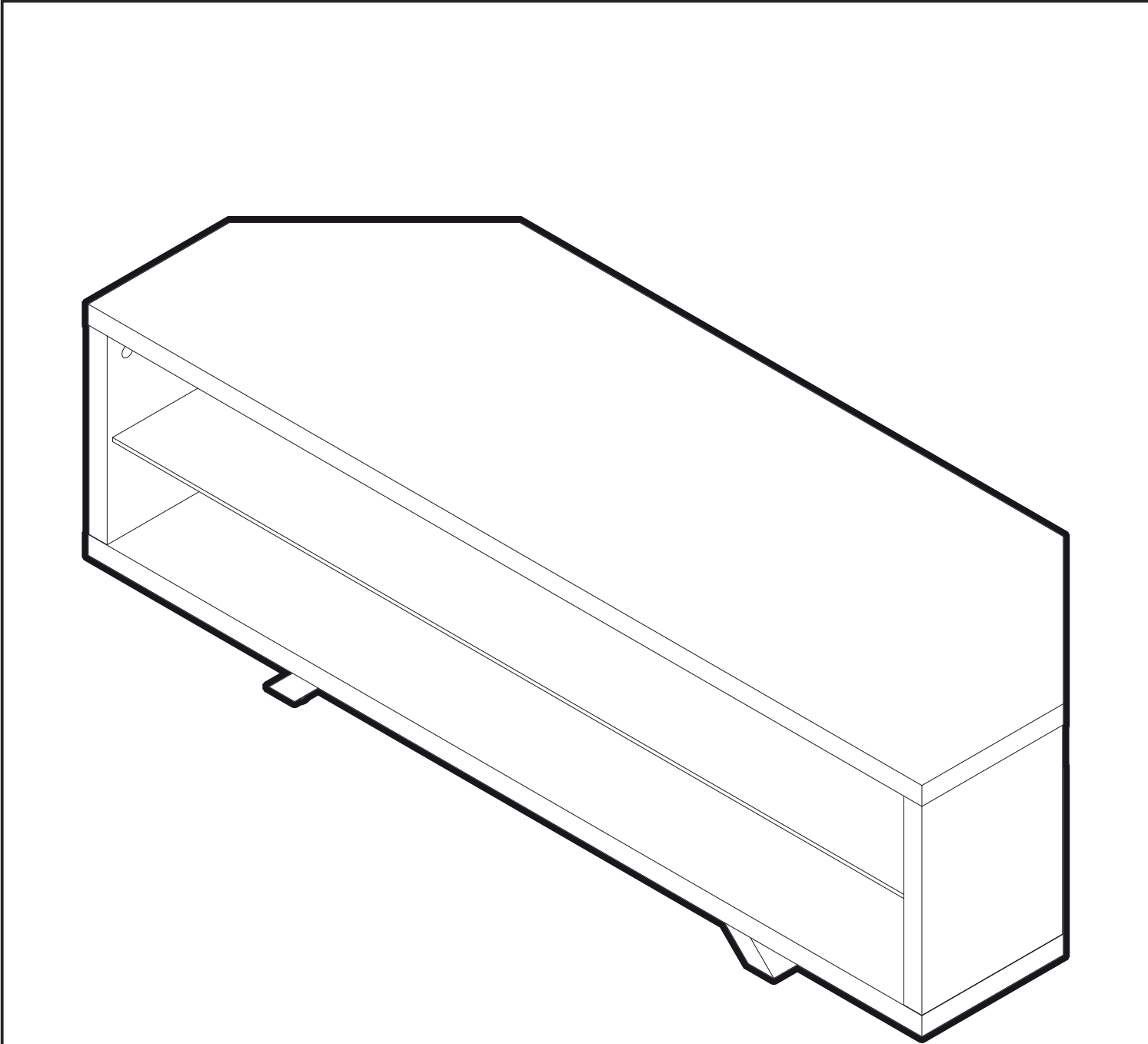

Care Instructions:

- This product uses real wood veneer. Slight colour change over time due to exposure to natural light is to be expected.
- Avoid direct sunlight as this can produce colour changes in the areas affected.
- Colour and pattern variation is to be expected with this natural material and does not constitute a product defect.
- Clean all surfaces using a soft damp cloth. A suitable furniture polish can be used if required.
- Do not use abrasive cleaners.
- Do not place hot or cold items in direct contact with any part of this product.
- Take care not to overtighten any part of this assembly.

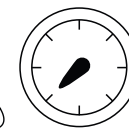

1 person = 30mins
2 people = 20mins



TECHLINK, A Division Of Tapehand Ltd.
Units 7 and 8 Bat and Ball Enterprise Centre
Bat and Ball Road
Sevenoaks
Kent
United Kingdom
TN14 5LJ



(UK) Free Phone 0800 634 2699
(US) Toll Free (844) 499-1159



spares@techlink.uk.com

Web

www.techlink.uk.com
www.recharge.uk.com

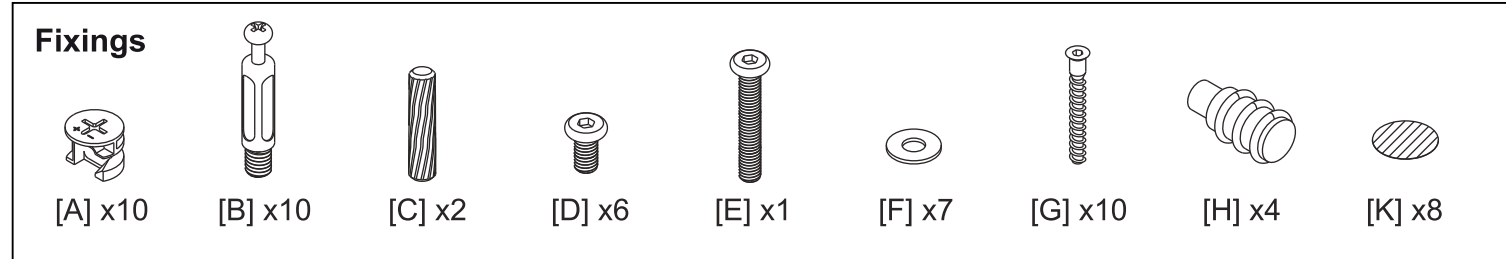
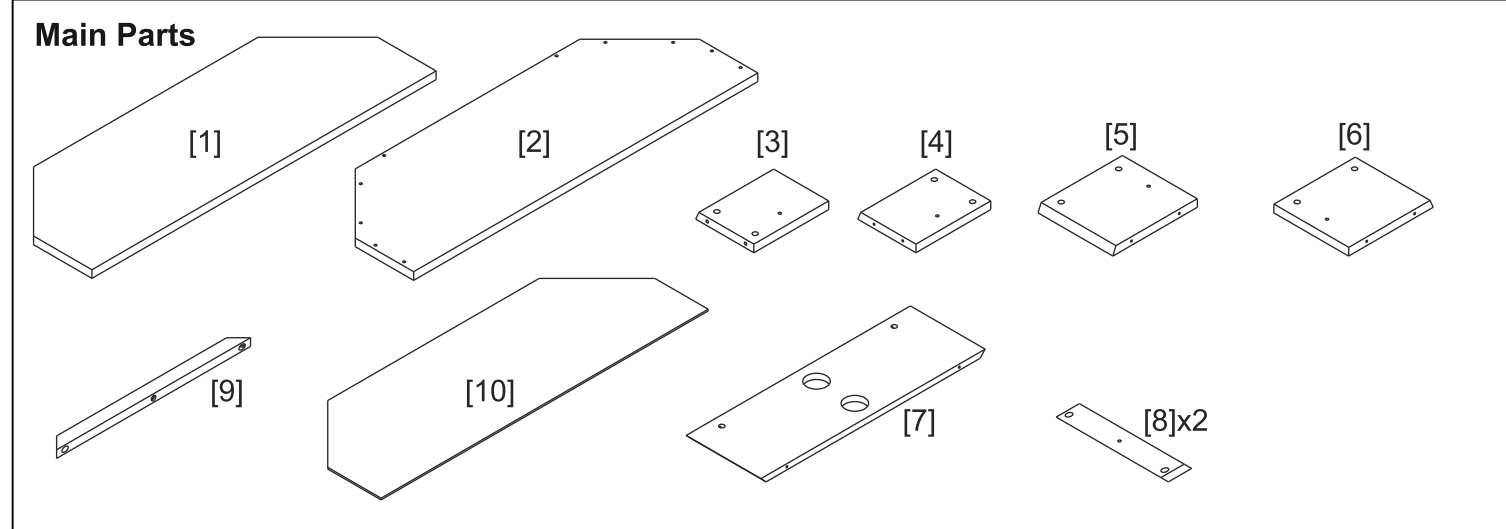
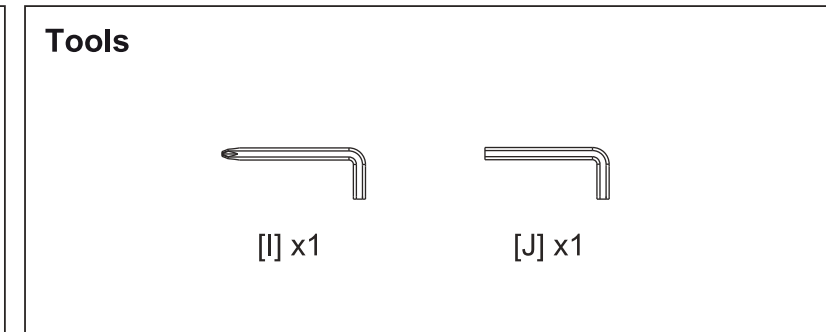
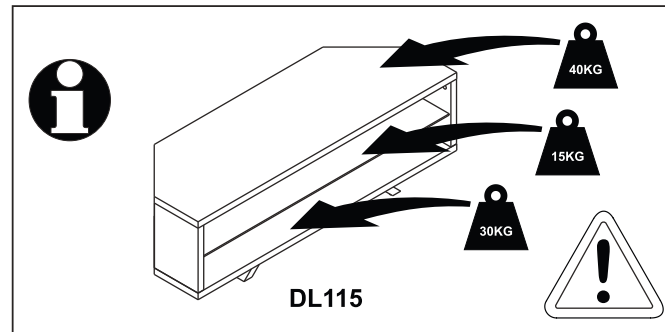
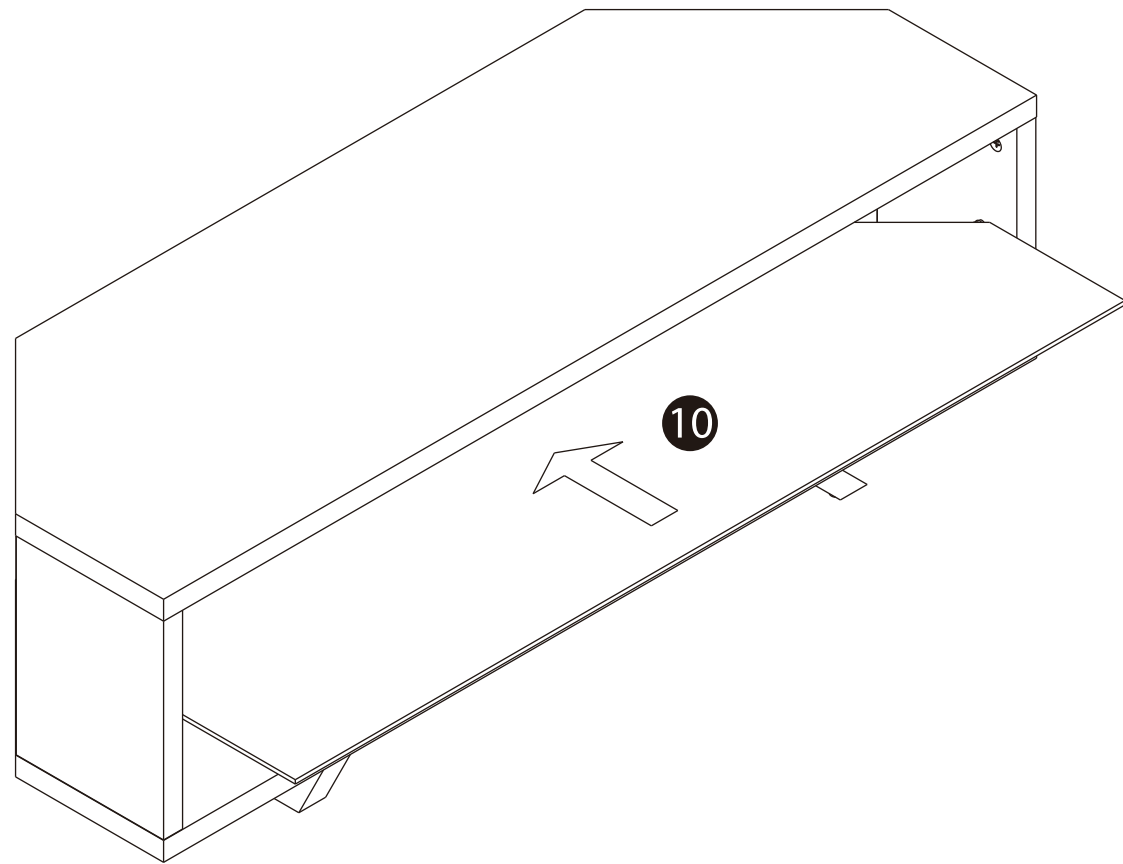

 **Take extra care not to over tighten any screws as this may cause damage!**

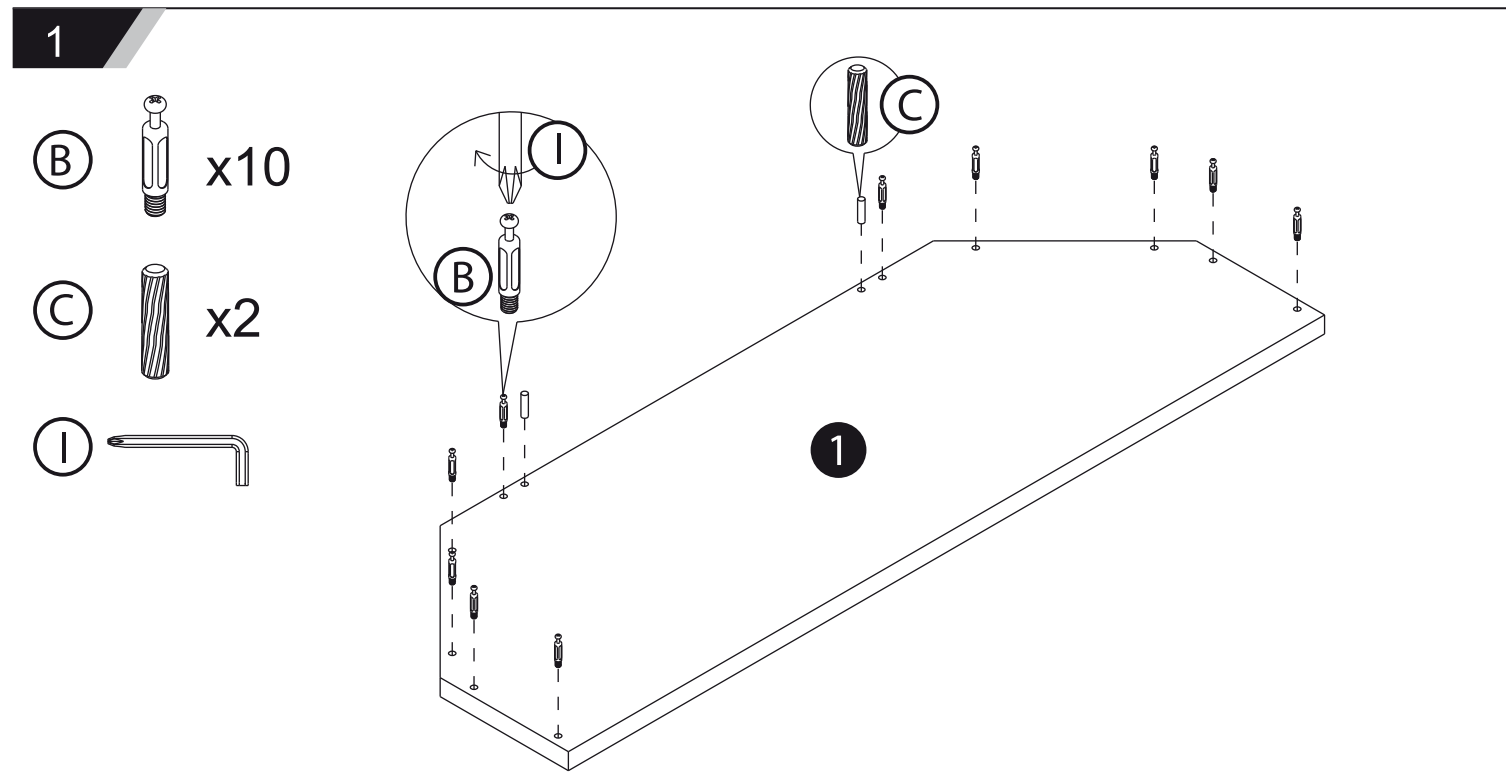

2

(A)  x8

(I) 

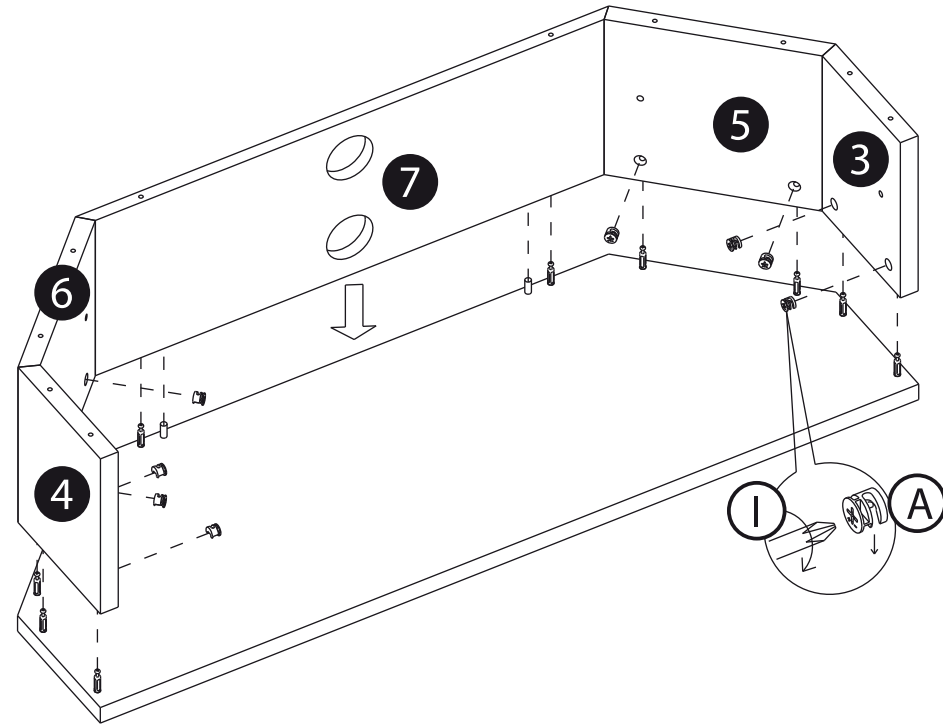

4

(D)  x6

(F)  x7

(E)  x1

(J) 

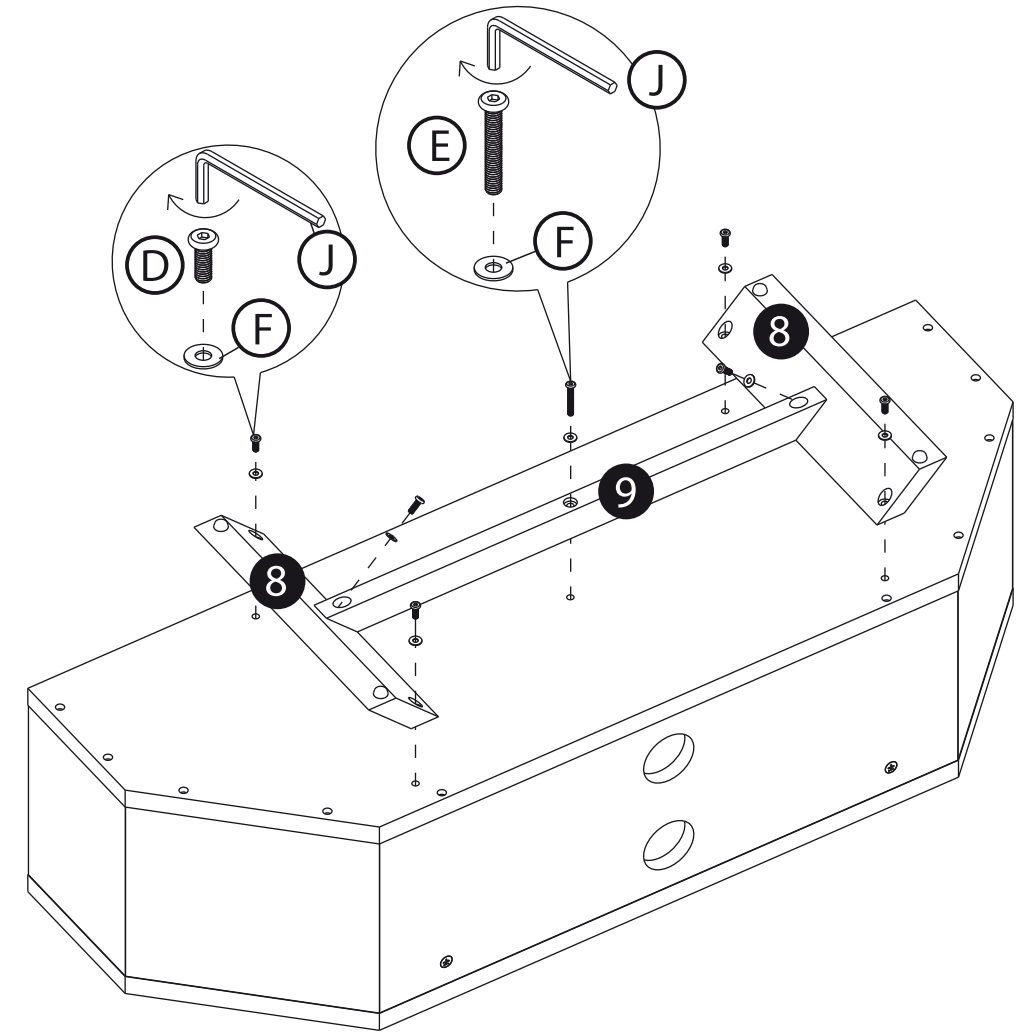

3

(A)  x2

(G)  x10

(J) 

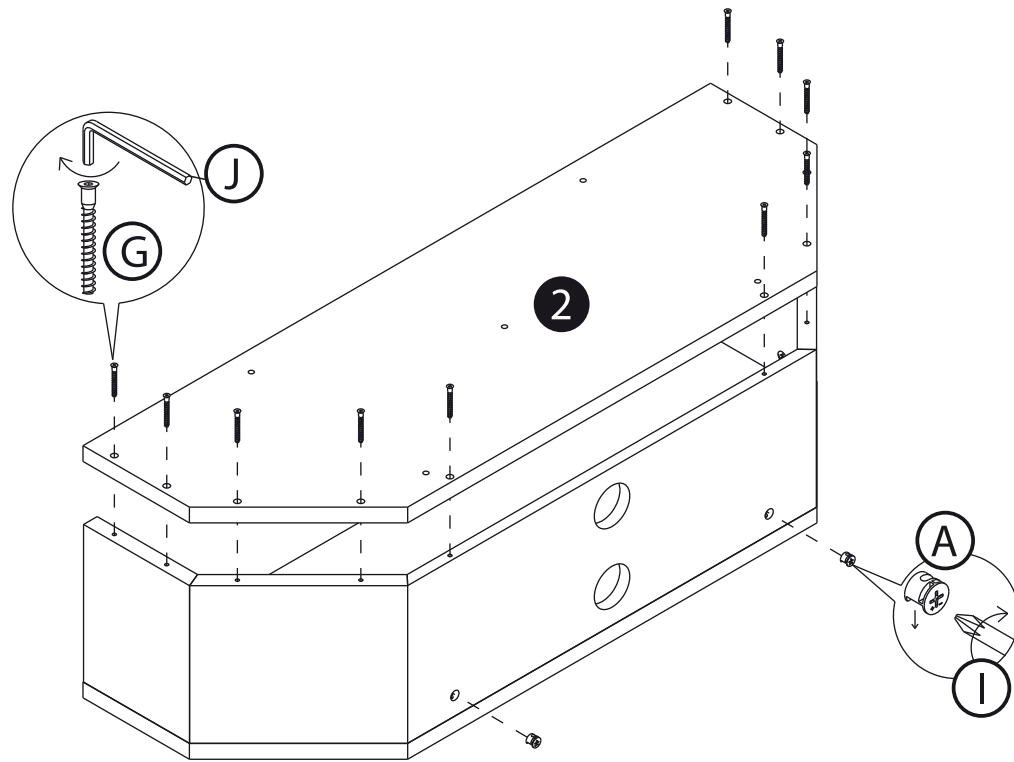

5

(H)  x4

(K)  x8

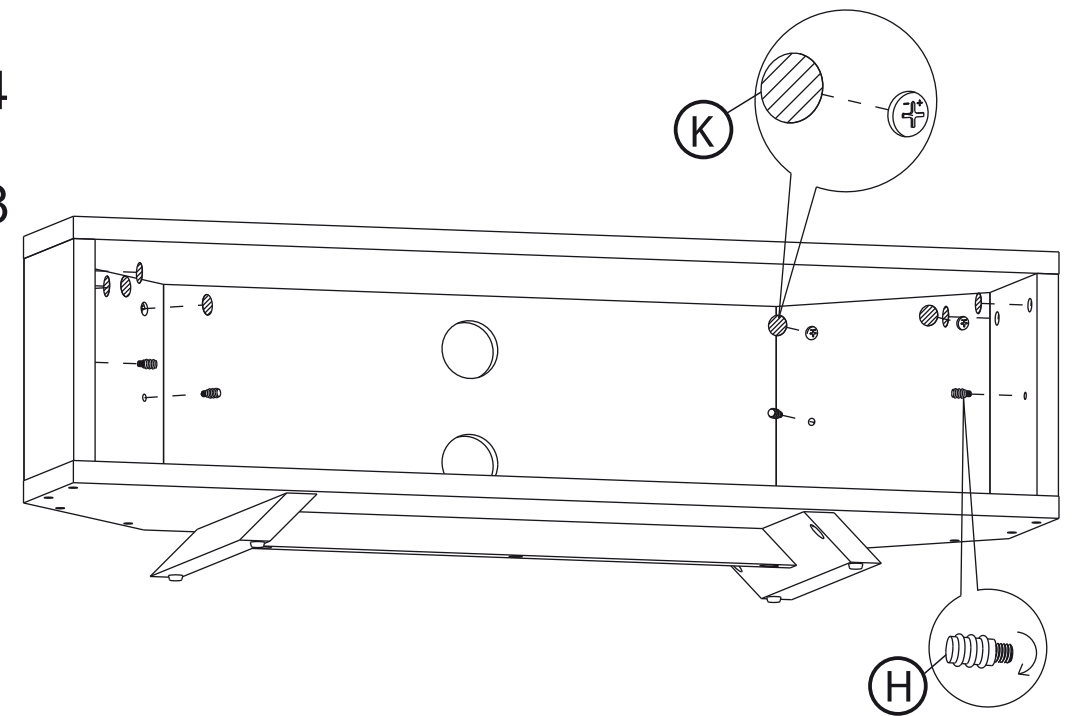

Caution when turning the stand over
best done with two people